



Oden Control AB



USER'S GUIDE

INSTALLATION AND

MAINTENANCE MANUAL

ODEN V-SERIES ACTUATORS



CONTENT

PAGE

1.	Content.	1
2.	General information.....	3
3.	Technical description.....	5
4.	Mechanical installation.....	8
5.	Electric connection	10
6.	The calibration system.....	11
7.	OVP – Oden Valve Program	13
8.	Maintenance	15
9.	Trouble shooting.....	16
10.	Tips, Recycling of the used Oden products and Fuses on connection board.....	18
11.	Actuator sizes and assembly connections.....	19
12.	Control signal and feedback connections	20
13.	Explanations for in and outputs on connection board	21
14.	Linear actuators. Sizes and technical drawings.	22
15.	OVP-V valve program installation help	23-24
16.	Lubricant recommendations and Warranty information.....	26

Appendix:

Technical specifications

Drawings

Electrical connection

NOTE! This manual is valid for Oden actuators with OVP-V version V5.0.23A firmware.

THANK YOU FOR YOUR INTEREST IN OUR ACTUATORS.

IF YOU NEED HELP TO CHOOSE ACTUATOR TO YOUR VALVE, READ THIS:
WE NEED FOLLOWING INFORMATION TO CHOOSE ACTUATOR, TO FIT YOUR REQUIREMENTS:

NEEDED INFORMATION:

1. REQUIRED TORQUE / FORCE (NM/ KN, ROTATING OR LINEAR)?

CHECK MAXIMUM ALLOWABLE FORCE/ TORQUE (FROM YOUR VALVE SUPPLIER) YOU CAN EXPOSE YOUR VALVE, TO AVOID DAMAGE.

2. REQUIRED SPEED (FROM CLOSED TO FULLY OPEN)?
3. PRESENT TEMPERATURE IN VALVE/ MEDIUM AND AMBIENT TEMPERATURE?
4. TYPE OF ACTUATOR CONTROL (4-20MA, 0-10V or 0-10V, 3-POINTS CONTROL OR OTHER)?
5. VALVE MANUFACTURER, TYPE AND SIZE?

DRAWING OF VALVE TOP (TO CHECK FOR EXAMPLE SHAFT SIZE, LENGTH, KEYWAY, SIZE AND HOLE CIRCLE FOR TOP FLANGE ETC). MAYBE ISO SIZE (F, F7 ETC.)?

OFTEN IT IS IMPORTANT TO KNOW, IF THERE IS REQUIREMENTS FOR THE ACTUATOR BODY MATERIALS. IN OUR ACTUATORS, ARE ALL PARTS IN ANODIZED ALUMINIUM MATERIAL. ANODIZED ALUMINIUM IS NOT RECOMMEND USING IN OFFSHORE OR IN AREAS WHERE EQUIPMENT CAN BE EXPOSED TO AGGRESSIVE SUBSTANCES SUCH AS ACIDS.

ODEN ACTUATORS CAN BE DELIVERED WITH HARD-ANODIZED PARTS, FOR BETTER RESISTANCE TO SALTY WATER AND OTHER AGGRESSIVE SUBSTANCES.

TAKE CONTACT WITH YOUR LOCAL ODEN ACTUATOR SUPPLIER OR ODEN CONTROL AB, FOR MORE INFORMATION!

WE HAVE ASSEMBLY KITS FOR MOST OF THE VALVE TYPES AND SIZES IN OUR STOCK. BUT TO AVOID LONG DELIVERY TIME FOR ASSEMBLY PARTS, PL. GIVE ALL TECHNICAL INFORMATION (AS VALVE TOP DRAWING) ABOUT YOUR VALVE/ APPLICATION!

IF YOU HAVE ANY QUESTIONS, PL. DO NOT HESITATE TO CONTACT YOUR LOCAL ODEN ACTUATOR SUPPLIER OR ODEN CONTROL AB. WWW.ODENCONTROL.COM

Actuators can be delivered with many diverse types of external gears, lever modules, linear units, turning modules and assembly kits.

NOTE!

This Oden OVP-V.23 program is compatible with Windows 7 Windows or newer versions.

Oden V series manuals are available in SE, DE, EN, RU, FI, SP, TR, and FR language.

Ask your local Oden dealer or Oden Control AB

General information

The Oden family of electric actuators

The Oden® family of electric actuators are made specifically for the process industry. The family consists of turning and linear actuators designed for the most demanding industry environments. The standard product line of electric actuators consists of five basic units in varied sizes. These basic units, combined with turning or linear modules, or added gears can be used for regulation of most types of valves on the market.

Oden actuator characteristic:	Oden actuator features:
– High accuracy	– Supply voltage 24V DC or 48V DC
– High gear efficiency	– Programmable by Oden Valve Program
– High reliability	– Automatic calibration
– Low weight, small size	– Several setpoint sources
– Temp. resistance -40 to +80 (inside temperature in the actuator)	– Fits most of the valves on the market.
– Low noise level	– ISO F connections to valves.
	– Long service life

All the Oden electric actuators are programmable by the OVP (Oden Valve Program) software. The actuator is pre-programmed with default data, unless set to the specific customer demand prior to shipment.

Summary of Oden product range

1.1.1 Turning actuators

Turning actuators	V30	V65	V180	V250	V400	
Torque (Nm)	6-30	10-60	30-120	60-300	60-400	
Speed Max. (degrees / sec)	25*	22*	20*	9 *	9 *	
Precision (°)	± 0.5	± 0.1	± 0.1	± 0.1	± 0.1	

*) Depends on chosen force and power supply (24V DC or 48V DC) If questions, take contact with Oden Control AB for more information.

When running actuators with 48V DC, it is possible to get approx. 50-100 % higher speed with V-models V30, V65, V180, V250, and V400!

1.1.2 Linear high-speed actuators and high-speed actuators

Linear actuators	V30QL	V65QL	V30Q	V65Q
Force (kN)	16 kN	30kN	6-30Nm	10-60Nm
Standard screw pitch (mm)	10*	10*		
Speed (QL mm/min) (°/sec)	400	250	250 °/sec	180 °/sec

OTHER SIZES of screw pitches also available, depending on needed force! Please contact Oden Control AB, for more information.

Terms concerning safety.

It is of utmost importance that all users are follow instructions on how to install, maintain and use this series of electric actuators. The safety terms DANGER, WARNING, CAUTION and NOTE are used in these instructions to point out dangers and/or providing additional information on aspects which are not readily apparent.

- DANGER: Indicates that death, severe personal injury and/or substantial property damage will occur if proper precautions are not taken.
- WARNING: Indicates that death, severe personal injury and/or substantial property may occur if, proper precautions are not taken.
- CAUTION: Indicates that minor personal injury and property damage can occur if proper precautions are not taken.
- NOTE: Indicates and provides additional information, which may not be obvious even to qualified personnel. Compliance with other, not particularly emphasized information, regarding transport, assembly, operation, and maintenance and regarding technical documentation such as operating instructions, product documentation or on the product itself is essential, to prevent faults, which may directly, or indirectly cause severe personal injury or property damage.

Operation and safety instructions

In English:

Read carefully, the manual before installation and operation as well as before maintenance. The actuator must only be used for controlling valves and similar applications. Incorrect use may harm the actuator. Hence, functions cannot be guaranteed. Local regulations concerning technical equipment's must be observed at installing or maintenance. Warning texts must be followed and necessary steps to prevent accidents must be taken. This manual is valid only with Oden V-series actuators.

In Swedish:

Läs noggrant denna manual före installation och idrifttagande liksom vid service av ställdonet. Detta ställdon får endast användas till att styra ventiler och liknande objekt. Felaktig användning kan skada ställdonet och därmed kan inte funktionen garanteras. Lokala bestämmelser beträffande teknisk utrustning måste följas vid installation och/eller underhåll. Varningstexter måste följas och nödvändiga åtgärder måste tas för att undvika olyckshändelser. Denna manual gäller bara för Oden V-serieställdon.

In German:

Bitte lesen Sie diese manual genau bevor der Installation und in betriebnahme. Gleichweise bevor Service von dem Antrieb. Dieser Antrieb darf nur benutzt werden für Steuerung von Ventilen und Gleichartigen Objekte. Falsche Verwendungen können dem Antrieb schaden und damit kann die Funktion nicht garantiert werden. Lokale Vorschriften betreffend die technische Ausrüstung muss bei Installation und/oder Unterhaltarbeiten beachtet werden. Warnungstexte müssen beachtet werden und notwendige Maßnahmen durchgeführt werden, um Unglücke zu vermeiden. Dieses Manual behandelt nur aktuatoren vom Typ Oden: V-Serie.

NOTE! (Information about the manual operation with handwheel)

If your electric actuator was delivered with handwheel or manual operation by hex key. Power supply to actuator must be switched off if the actuator will be operated manually. When the actuator is operated manually with handwheel or with hex key, torque will be about 10 times higher than actuator own torque. Wrong handling can damage stepper motor shaft, control board and gear. See closing direction on yellow sticker on actuator top or handwheel top.



TECHNICAL DESCRIPTION

General

The Oden V-series module system consists of:

- Basic Unit
- Turning or linear module
- Valve adapter
- Connection board

Product	Basic Unit	Module	Remarks
V30 to V400*	V30 to V400BU *	V30 to V400R*	Turning actuator
V30QL and V65QL	V30 and V65QL BU	V30QL and V65QL	Linear actuator high speed
V30Q and V65Q	V30 and V65Q BU	V30 and V65QR	Turning actuator high speed
*All models			

Basic unit

The basic unit has a sealed aluminum housing which includes a step-motor, a reduction gearbox, electronic and a connection board with a terminal block. The reduction gearbox is based on the patented Oden-principle and has a reduction ratio of 100:1. The hand-wheel at the top (option) of the unit is engaged by pushing it in. NOTE! the warning sign and only use hand wheel in case of emergency when power is off.

The electronics with all its power and logical components, are placed inside the unit, close to the motor. No batteries, potentiometers, limit switches or other sensitive electro-mechanical components, are used. The step-motor is fed by 24 or 48V DC. The control signal can be selected with OVP program.

The actuator should not be placed in a control system with a feedback loop, i.e., the feedback signal must not be reconnected to the control signal.

Cables for power and control signal should be connected through the cable inlets on the removable lid, which hold the connection board. The cables are not included in delivery. When selecting cables, choose one or two cables with shielding. The diameter of the cable/cables should be about 4-10 mm. For more information and examples of suitable cables, see section 5.

All parameters such as torque, speed and working range are set by the OVP-V software (Oden Valve Program). Features, such as automatic power calibration, automatic time calibration and the shut off function can be adjusted or disabled in OVP-V program. The parameter settings in the software are stored in a permanent memory and cannot be lost even during an extended power failure. The current position will be automatically saved in a permanent memory during a power break. If the power break does not exceed 600 hours, any movement of the actuator will be detected and added to the position memory. This means that the hand wheel can be used without the risk of losing the calibration point at closed position. However, if the power break lasts more than 600 hours, the actuator will perform an automatic calibration when power returns (if selected in OVP program. Go to section 6 for more information about calibration methods.

Oden actuators can be supplied with local control with push buttons (optional). You activate and deactivate, local control with magnet. You can open and close the valve with the two buttons. The LEDs light up when the open or closed position is reached. The function of the lamps can be changed in the Oden OVP-V program. Local control fits all Oden actuator models.



Turning module

The turning module consists of a gear wheel, working as an inner part of a gear coupling, and two indicator / Allen bolts, firmly fitted and locked by Loctite. The indicator Allen bolt heads operate as rough visual valve position indicators as well as internal mechanical stops.

The turning module must be machined, to fit to the actual valve spindle. Normally it should have a round hole with a keyway, but also square or holes with splines, are common.

Sometimes is better to use a tapered clamping sleeve. These make the installations quicker and easier. See picture in page 9.



Turning adapter kit

The valve adapter will vary depending on valve type for the models from V30R/V30Q to V400R.

Linear module (for actuator types: V30QL and V65QL)

The unit consists of anodized aluminum housing with a ball nut and a ball screw, a thrust bearing, and a protective rubber bellows. The ball screw of the linear module has small backlash and has a preloaded double row angle contact ball bearing which will take the high thrust forces.

The outer end of the screw, which is not rotating and just making a linear movement, has a clamping device (rotation stop) which connects the valve spindle to the linear unit ball screw thread. This device must be machined with the same thread as the actual valve spindle.

The clamping (rotation stop) device is sliding along one of the two bars which have a flange fitted at their outer ends. The flange will vary depending on valve type.

See page 22 in this manual.

Linear adapter kit (for actuator types: V30QL and V65QL)

The linear adapter kit consists of:

- Two spindle adapters (rotation stop)
- Flange adapter
- 2, 3 or 4 rods
(Depending on valve type and size)
- Screws



The flange adapter is processed by a machine. to fit the actual valve flange / valve top and the rods have a specific length for the actual valve. The clamping device, to valve side, must be processed by a machine. to the same thread as the actual valve spindle.

See page 22 in this manual!

Connection board.

Connection board CT1296 I is standard and included in delivery. See page circuit diagram on page 20.

Standard connection board

The connection board is placed on the inside of the terminal lid, on the side of the actuator. The board has three separate terminal blocks with inlets and outlets, marked with numbers. Power supply 24V DC or 48V DC to terminal block P3 and control signals to or from terminal block P1. Modbus connections to P2.

A diode on the connection board protects the electronics from a polarity switch on the power inlets (24 / 48 V DC). However, the control signal inlets, are not protected; make sure to follow the wiring instructions.

WARNING: 24V DC or 48V DC at the control signal 4-20mA (pins 7 and 8), inlet will result in irrevocable damage to the electronics. 48V DC at the control signal inputs and other signal inputs, will result in irrevocable damage to the electronics. **(Do not connect 48 V DC to pins 1 to 16 on connection board)**

Maximum input to pins 2, 3, 4, 5, 11, 12, 14 and 16 at terminal block P1 is max 24V, max I=120mA

Read LIMITATIONS FOR IN AND OUTPUTS document, download from www.odencontrol.com

OVP-V (Oden Valve Program for V-series actuators) and USB / MINI USB cable

Standard actuator is programmed with default values of torque, speed, and working range etc. These settings can be changed by using the OVP-V software (Oden Valve Program). The software can be installed from the CD delivered with the actuator. Please ask for software from the manufacturer or supplier, if not delivered with actuator!

Actuator has MINI USB connector at control board and can be connected to computer with USB/USB MINI cable. The computer cable is optional and not included in delivery, if not separately ordered. Please contact your Oden dealer if you wish to order.

For further information about OVP-V, go to section 7.

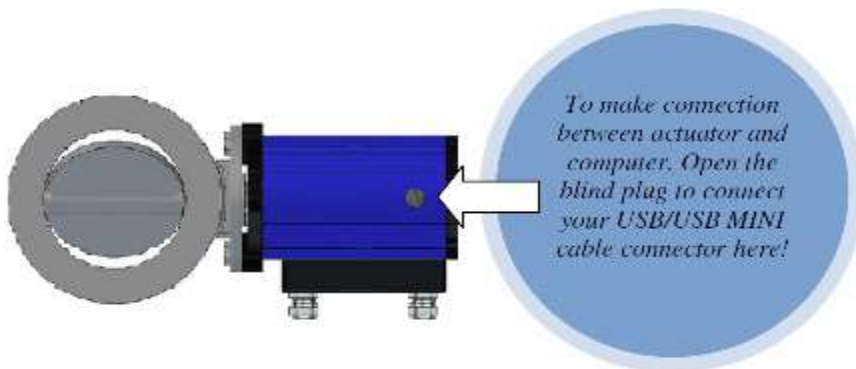

IMPORTANT!

PUT IN USB MINI CONNECTOR FIRST IN ACTUATOR AND THEN TO COMPUTER. OPEN THE PROGRAM BY CLICKING OVP PROGRAM ICON. CLICK ONCE THE GREEN PAUSE ICON, MAKE REQUIRED SETTING CHANGES, THEN CLICK APPLY AND SAVE (NO YELLOW PUSH BUTTONS LEFT IN ANY PROGRAM MENY) THEN CLICK GEEN RUN ICON TO COME BACK IN TO REMOTE MODE.

MECHANICAL INSTALLATION

The examples in this chapter should be regarded as guidance only. Actual installations may vary depending on the type of valve used. Some adapter consoles and screws might differ from those described below.

NOTE: *The manufacturer warranty will be void if the cover is dismantled.*

WARNING: *If the 24 or 48V DC is connected during assembly or function control, the valve may move.*

Confirmation of delivered items.

Please check that the delivery is complete according to the delivery specification:

- Basic Unit (V30 to V400)
- Turning or linear module (V30QL, V65QL)
- Product certificate
- User's guide
- CD including software OVP (Oden Valve OVP-V23A Program+ manual in different languages)
- Computer cable USB/ USB MINI (option)

Tools

- Allen keys (metric)
- Spanners (metric)
- Blade screwdriver
- Loctite 243

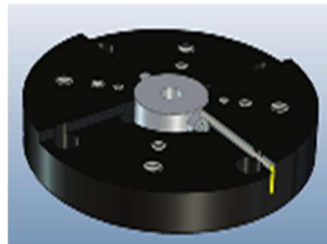

Actuators can be delivered with position indicators, which are visible outside of actuator (option). See picture above.

Installation of turning actuators

The following installation instruction refers to the standard turning module described in section 3. When using the tapered clamping sleeve leave out the section about machining the turning module. Contact Oden Control for more information.

Fitting of the turning module

1. Machine the turning module with the pins attached to a close fit to the valve spindle shaft and key. The keyway in the turning module must be machined in the correct position in relation to the indicator pins.
The figure shows a V-series turning module machined to fit a valve spindle with a diameter of 25 mm and a keyway. Note the position of the keyway at 45° to the pins. For most valves, the position of the key at the valve spindle is placed in 90° to the flow direction in the valve when the valve is closed.



NOTE: *When the valve is in closed position the indicator pins must be in 45° to the valve.*

2. After machining the keyway, clean the top surface of the turning module, put Loctite sealant to the inside edge and place the washer with the convex surface turned outwards. Use a hammer or a hand press to seal the turning module by deforming the washer.

NOTE: *The washer must be mounted in accordance with this instruction to meet IP67 regulations (warranty condition).*

3. Fit the valve flange adapter to the valve flange.

4. Check that the spindle length above the valve flange adapter is within A max and A min, see table on the right.
5. Check also that thickness of valve shaft is suitable for turning module. B max shaft size
(If possible, use standard parallel key and keyway)
6. Move the valve to closed position.

Type	A max (mm)	A min (mm)	B max shaft Size (mm)
V30	37	15	16
V65	52	20	25
V180 and V250	79	30	30
V400	114	50	50

NOTE: Some valve shafts change the axial position in the closed valve position.

7. Attach the protection plate to the valve flange adapter and then fit the turning module. Use a hand press or a similar tool to push it in position. The indicator pins should now be in 45° to the valve.

The correct axial position of the turning module is important. The bottom surface of the turning module must be at the same level as the top surface of the protection plate when it is placed at the valve flange adapter. The tolerance should be 0 - +1.5 mm (above the protection plate surface).

NOTE: It is important to have a tight fit to the spindle and keyway to benefit from the accuracy of the actuator. Don't use hammer, this can damage the valve spindle.



Ask for information for tapered clamping sleeves, for assembly without the keyway.

If you are using stop screws you will reduce the free working angle. There is a risk that the bolt heads will hit the mechanical stops before the actuator has reached the maximum opened position (normally 20 mA). This must be avoided by reducing the programmed working range in OVP-V.

FITTING OF THE ACTUATOR:

1. If the rotary module is to be mounted directly on the valve spindle, leave maximum gap of approx. 1.5mm between the rotary module and the valve breast. Lock the rotary module to the spindle if a stop screw is mounted on the rotary module. If yoke has been mounted between the valve and the actuator, the distance between the top of the yoke and the rotary module may be no more than 1.5mm, so as not to damage the actuator.
2. Carefully place the actuator in place by turning it slightly in both directions, to get the actuator gear sleeve and the rotary module in the correct position to each other. An air cushion effect can prevent assembly, but the air disappears after a while.
3. Use the handwheel or allen key to smoothly turn the actuator in the correct position for the screws in relation to the valve breast holes, actuator threads or any adapter flange threads.
4. When the valve is closed, check that there is a distance of at least 2 mm between the bolt heads indicator and the mechanical stops in the Oden actuator. For ball valves without mechanical stops in the valve, the closed position will of course be when the indicator bolt heads hit the mechanical stops in the actuator.

Mechanical control

The hand-wheel is engaged by pushing it in with allen key or hand wheel Option). Notice the warning label at the hand-wheel. Careless handling will damage the valve or the actuator. **The hand wheel must not be used when the power supply to actuator is on.**

NOTE: The hand-wheel moves in the opposite direction than the valve.

Please, check that the actuator can be operated easily by hand within the whole working range. The valve must be closing completely. It should be running smoothly. If not: loose the adapter screws and let the unit center itself, then tighten alternately the screws. If the actuator is horizontal, relieve the weight of the actuator manually during alternately tightening of the screws.

It is not necessary to align the Oden actuators to the valve by using shims. For other types of actuators can this alignment process be tricky, and you get easily an uncontrolled loading to the valve spindle bushings and the gland sealing. Hence the Oden actuator significantly improves the lifetime of the valve.

Installation of linear actuators

1. Check that the spindle adapter (rotation stop) on valve side, has the same thread as the valve spindle.
2. Fit the linear module with its rods and adapter flange to the valve flange/valve top.
3. Put the valve spindle in maximum opened position. Fit the valve spindle to the ball-screw by the spindle adapter.
4. Check by rotating the gear coupling in the linear unit that it runs smoothly in whole working range and that there is a small guiding play between the spindle adapter and the rod.
5. Fit the Basic Unit to the linear unit by the enclosed screws and washers.

NOTE! Check that the set working range in OVP-V, is within the mechanical working range of the linear module

ELECTRIC CONNECTION

Cable connection

1. Remove carefully, the terminal lid and disconnect the ribbon cable and twisted red and black cable (VD and GND cables from connection board to the control board)
2. Put the shielded cables through the cable inlets and connect the wires to the terminal block at the connection board.
3. The cable shield should be connected to the cable inlets which are grounded to the actuator housing. Note that the cable shield should only be fitted to the grounded cable inlets. Not in the free end of the cable.
4. Connect the ribbon cable to the connector. Do not force it in the wrong way.
5. Check that the voltage is 24/ 48V DC, and the wires, are correctly connected to the terminal block. **NOTE! 24V DC or 48V DC (you must select in OVP program which will be used)**
6. Connect the ground cable from the terminal plate to a suitable ground point on the valve or equivalent.
7. For more information about electric wiring, go to Appendix.

See also separate data sheet for input/ output limitations (download from Oden Control website)

DANGER: The cable between the actuator and your connection terminals must be clamped (fixed installation).

*DANGER: Check that the voltage is 24V DC / 48V DC, and that the wires are correctly connected to the terminal block. (Pins 1 -3 on connection board) **Please, verify polarity to avoid damage!***

NOTE: Do not connect the cable shield(s) to ground in the free end of the cable(s).

NOTE: Do not twist the cable(s) in the cable inlet(s).

NOTE: If only one cable inlet is used, the other one must be plugged by the enclosed rubber washer (warranty condition).

Voltage drops:

If a long cable is used between the power source and the actuator you need to calculate the voltage drop.

The maximum power peak current*:

- V30: 5A* V65: 5A* V180: 7A* V250: 10A* V400: 13A*
- V30Q: 10A* V30QL: 10A* V65Q: 13A* V65QL: 13A*

***When maximum torque is selected for specific actuator!**

Use a cable which gives a voltage drop of max 2V. A bigger drop will reduce performance and may affect the function of the electronics.

It is possible to compensate for the drop by raising the voltage at the power source. However, be careful not to exceed 48V DC at the power supply terminals on the connection board

The return (position) signal circuit should be loaded by about 250ohm. (Max 350 ohm).

Choice of cable

Cable for power supply should have conductors with each 1,5 mm² cross-sec. Actuator types V400, V65Q and V65QL should conductors be with each 1,5- up to 2,5 mm² cross-sec, max cable length between power supply and actuator is more than 5 m, twisted cable when 13A current. Our connection board inlets can take max conductors with each 2,5 mm². Ask your actuator supplier for more info.

THE CALIBRATION SYSTEM

To calibrate the actuator/valve-system means to find the closed valve position which corresponds to the closed position of the control signal, normally 4 mA. The Oden calibration system PC/PC means power calibration.

The position value will be automatically saved to a permanent memory during a power failure, see 6.3 Summary of calibration methods. The position value will never be lost even during an extended period of a power failure. If the valve position has been changed during a power failure, the motion will be detected and added to the saved value. This detection occurs during max. 500-600 hours after a power failure. When the power returns, an automatic calibration will be performed (only if the last calibration was a Power Calibration).

Calibration

Automatic Power Calibration

An automatic Power Calibration performs every time the valve reaches its closed position. The electronics will remember the calibration position even after more than 600 hours power failure. When the 24/48 V DC power has returned, a new automatic calibration (Power Calibration) will be performed automatically. This calibration routine can be disabled in OVP-V (Oden Valve Program)

The reason for this routine is to make sure that the valve is in its closed position and reducing the risk of jamming. Valves may jam depending on a change in the ambient temperature distribution in the valve.

If more than about 600 hours of power down has elapsed an automatic calibration will be conducted when the power returns. The calibration will last about 5 seconds. After calibration, the actuator will respond to a control signal if present. The maximum opening angle, starting from this closed position, is either set by default or by the customer in the OVP-V software. The Power Calibration will be carried out with 80 percent (can be adjusted) of the programmed control torque. **This function can be disabled in OVP-V program.**

Manual Calibration

If you want to perform a calibration within about 600 hours after a power failure or for any other reason, please do as follows:

1. Connect your actuator with computer and open OVP-V program. Power supply and control signal IN must be on. **NOTE! Always connect USB cable first in actuator, then in your computer!**
2. Wait couple seconds, sometimes your computer will activate used USB port first.
3. Check in OVP window if you really are in contact with actuator!
4. Now you can open Settings window and press PAUSE and then START CALIBRATION. Now actuator performs the calibration. When ready, press RUN.

5. In this SETTINGS window you can change basic settings for your actuator type.

Manual calibration without computer- see page 21!

The calibration values are stored in permanent memory in the electronics.

Summary of calibration methods

Type of calibration	Automatic/Manual	Description
Power Calibration	Automatic	Automatic (auto init after long time power loss) Choose in settings window <ul style="list-style-type: none"> When power return after > about 600 hours Actuator keeps position in memory about 600 hours If you do not move the hand wheel!!
Power Calibration	Manual	Manual start of Power Calibration: <ul style="list-style-type: none"> Press: PAUSE then START CALIBRATION in SETTINGS menu / OVP-V -23 program
Power Calibration	Without computer	See instruction page 21!
Init	Manual	Quick calibration of closed point (settings menu)

START MENU:

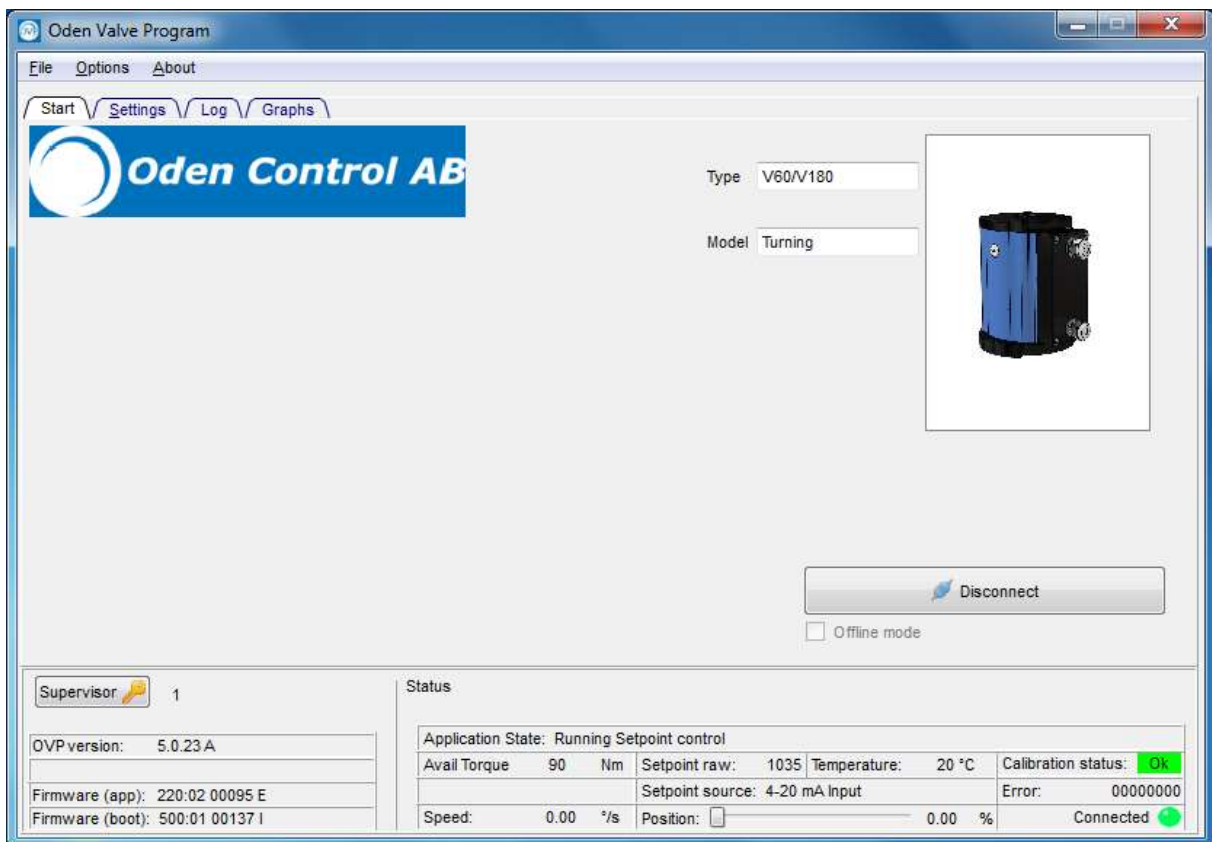

OVP-V ODEN VALVE PROGRAM

THE ODEN VALVE PROGRAM, OVP, CAN BE USED TO CHANGE THE DEFAULT SETTINGS OF TORQUE, SPEED, WORKING RANGE ETC. HOWEVER, IT IS NOT REQUIRED FOR OPERATING THE ACTUATOR. IF THE DEFAULT VALUES ARE ADEQUATE FOR YOUR APPLICATION, IT IS NOT NECESSARY TO USE THE SOFTWARE. A LIST OF DEFAULT VALUES CAN BE DOWNLOADED FROM OUR WEBSITE.

The actuator parameters can easily be changed by any of these two methods:

- making the changes interactively in the program with the actuator connected to the PC.
- remotely on a separate PC by saving the changes in a data file and later loading them to the actuator when it is connected to the PC.

The software communicates with all Oden® actuators, using the USB/ USB mini cable. The available languages are Swedish and English. The OVP runs on any PC with Windows 7 and later versions. Latest version of OVP-V program is available on our website: www.odencontrol.se (normally delivered by actuators).

Main menu

The START menu of OVP contains actual valve model and type. You can also learn about the program in OFFLINE MODE: Up in the left corner you can find: FILE, OPTIONS and ABOUT menu, under FILE, you close the program, Under OPTIONS you can find OVP basic settings like language, speed units and font sizes. Under ABOUT you can read what version of OVP you have. Check that you have the latest version.

SETTINGS MENU:

You do not need any SUPERVISOR password to change or see basic settings in settings menu.

Settings menu appears after pressing CONNECT push button. Here you can see actual settings, change settings, and make manual calibration.

Parameter settings

To change settings in real-time the computer cable must be connected to the computer/connection board. Check that OVP can detect connection with the actuator (green dot in left corner).

It is possible to program a new set of parameters and submit the values later. In that case, check that the computer cable is removed from the computer/connection board and that the dots flash in green in the OVP window. To save settings, use the “APPLY and SAVE” button. Do not leave any “YELLOW” push buttons on window.

WARNING: When the actuator in contact with the computer, a change of a parameter in OVP-V will be conducted instantly.

A list of the changeable parameters and OVP-V functions follows.

- **Valve closing direction**
Sets closing direction. Viewed from the actuator towards the valve. Default - clockwise.
- **Loss of control signal**
Decides what happens when control signal is lost. Actuator will open, close, or stand still. Default is "unaffected". You can select 3-points control, if control mode is 4-20mA only. Useful when using external manual control box.
- **Closing torque / force**
Set max. torque / force, for closing.
- **Control torque** Sets max torque when the valve is moving to open or close direction.
- **Holding torque** Should be same as closing torque. (Can be selected only in V models, not VQ)
- **Auto init after long time power loss.**
A process to find the closed valve position. Two choices: on or off
- **Auto init once** When you select this function, actuator make the calibration once when power supply turns ON. **This occurs without warning.** Selected choice will disappear by itself after init!

- **Position recovery after power loss** Actuator will move to last known position for present control signal.

WARNING Actuator (even valve) goes automatically to closed position when the power supply returns.
If *Auto init after long time power loss* or *Auto init once* is selected!

- **Max. Opening angle /Full stroke**
Sets of the working range.
- **Signal level at maximum opening**
Can be changed in SUPERVISOR menu. Take contact with your Oden actuator dealer for more information.
- **Max Speed**
Sets operating speed.
- **Acceleration**
Can be changed in SUPERVISOR MENU. Take contact with your Oden actuator dealer for more information.
- **Shut-off**
When the valve is near its closed position, cavitation may occur which will damage the valve. When reaching the programmed "shut-off"-% value (% of the working range), the actuator continues to the closed position. Therefore, there will be a delay before reacting to the control signal when opening from closed position. Default is 0, 0%.

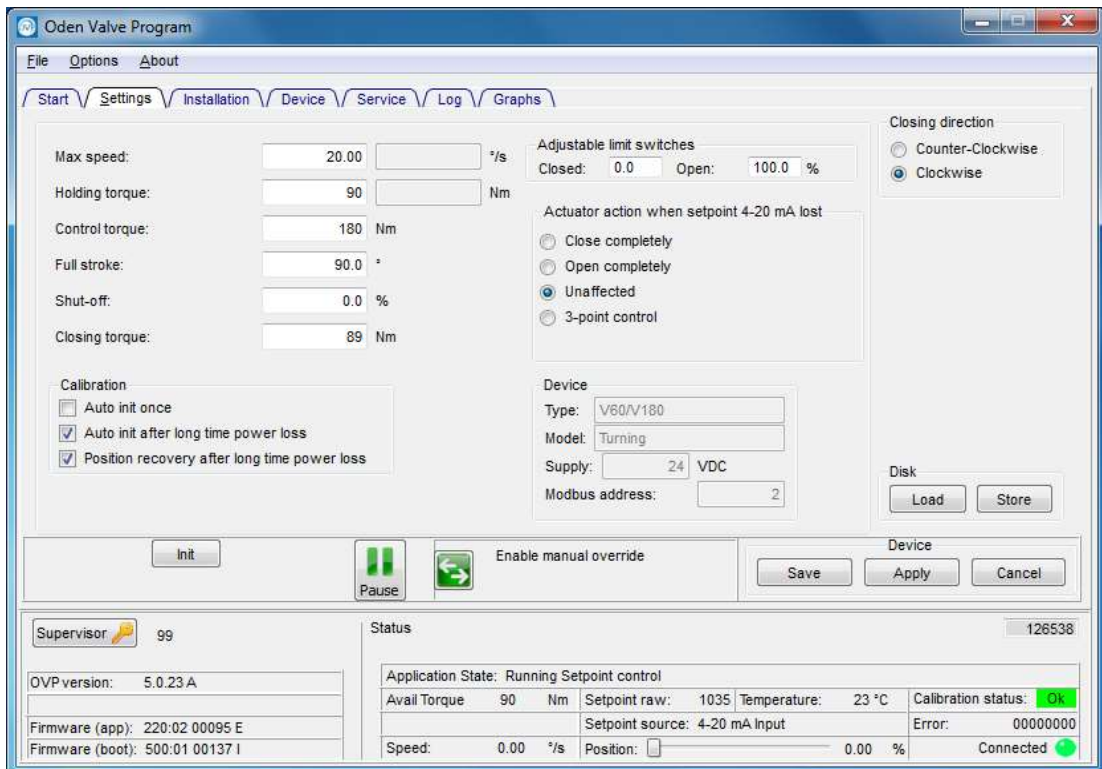

- Check Firmware (app) and Firmware (boot) are visible, when using V5.0.23A program.

Manual override: Press once green push button with arrows, beside the text. Enable manual override.

Wait until: MANUAL OVERRIDE starts flashing in STATUS field. Now you can run the actuator with green push buttons (push buttons with motives of open and closed valve), to open or closed position.

You can see feedback position in %, at the bottom of the window. To come back to normal control mode: click: X

Manual override stops now flashing.

Electrically adjustable limits, see page 15.

Maintenance

Control and function test should be conducted, only in every three years. In case of heavy loads of the actuator (and the valve) the intervals should be shorter. The Oden actuator gear and the bearings are lifetime greased and need no service.

Check points.

Electronic contact control

Control and clean the surfaces in the terminal blocks at the connection board.

Torque control

With the OVP software, it is possible to control the condition of the valve by slowly increasing the control torque/force until the actuator starts moving. You can then notice a change in valve bearing condition. The results of these controls can be written down in the notepad in the saved OVP data file.

CAUTION: This test must be done with the gland nuts slightly released, because these will affect the torque.

Calibration control

Perform a new OVP-V calibration by computer or manually without actuator. See instructions on page 22.

Position control

Position the valve near the middle of the working range. Increase the control signal very slowly until the valve spindle starts to move. Read the mA-value. Decrease the control signal very slowly until the valve spindle starts to move in the other direction. Read the mA-value. The signal difference is a measure of the “control backlash” of the system (positioning accuracy).

First check that it is no mechanical backlash in the coupling between the valve spindle and actuator. It is possible to measure the valve motion by using an indicator clock against a pin fitted to one of the free M10 threads in the clamp collar (turning valve). A common cause for backlash is that the spindle adapter is not properly fixed to the valve spindle.

Note that in some applications most of the total mechanical backlash in the system is eliminated by the media in the pipe system which will give a torque/force load at the valve spindle always in the same direction. Hence, this test should be performed on a normally pressurized system. Some valves have high internal friction. In such valves the backlash will have a direct influence on the positioning accuracy.

NOTE! Feedback signal OUT: Max loop resistance is 700 Ω (TBC) Accuracy: $\pm 0,05$ mA.

Electrically adjustable limits:

Go to INSTALLATION MENU. Press **PAUSE** push button. Select **CALIBRATION METHOD:” CLOSED”** and **“OPEN”** to **“SET MANUALLY.”** Press: **APPLY and SAVE**

Press once **CALIBRATION** push button. **Text area next turns to yellow.** Text **SET OPEN ENDPOINT** appears.

Wait until push buttons for open and close became green colored.

Move actuator position to needed (CLOSED) position by green (OPEN) push button. Press once round **CALIBRATION** push button. Please wait, message appears.

Text area next turns yellow with text: **SET OPEN ENDPOINT.**

Now you can move actuator position to needed open position (angle) with **OPEN** and **CLOSE** push buttons.

Press once **CALIBRATION** push button and wait until **RUN** push button appears.

Press once **RUN** push button and actuator goes into normal operation mode.

Trouble shooting

When problems occur, begin with checking that the unit is correctly mounted and that the parameter settings are suitable for the application. If you have trouble with older installations, it is often related to the valve. Check that the valve is not jammed or blocked for some reason.

Mechanical problem

The interface between the actuator and the valve can cause problems depending on the lack of standards for valve flange and spindle. Oden Control can offer adapters for almost all types of valves. It is important to check that the right adapter is used. Check that the right valve closing direction, torque, speed and working range have been chosen.

If the actuator hits a mechanical stop in max opened position (normally 20 mA) and the return signal is changing to error signal (2 mA), check that the valve is in closed (calibration) position at 4 mA (normally setting). Verify that the working range setting in OVP is correct. It is important that this working range is smaller than the maximum mechanical moving range in the valve.

Control problem

If the actuator does not react on a control signal, please do as follows:

1. Check power supply to actuator, (24V DC or 48V DC)
2. Check if green PAUSE push button is visible in OVP program, when the actuator is connected with computer. If the green RUN push button is visible, click it once so green PAUSE will be visible. Now actuator reacts for the control signal.
3. Check that there is a control signal reaching the actuator. Check if any setpoint source is selected in program.
4. Note that the shut off function closes the valve if the control signal is lower than 5% of the working range. This means that the actuator will not react on a control signal within this range.
5. Remove the top lid (lift straight up carefully) (if there is hand wheel or key grip, do it more carefully)!
6. Check the LEDs (light diodes).
 - If no LED is activated, check the power, 24V DC / 48V DC Check even fuses on connection board!
 - If the red LED is activated, break the power, and wait a few seconds before restoring power (24 V DC).
 - If the green LED flashes, check if you have control signal to actuator or perform a power calibration. If there still is no reaction to the control signal, the valve might be blocked or jammed. If the valve is blocked, the position signal (return) will go to 2 mA (default).
7. If the green LED is activated and measures made as described above, but still nothing happens, connect the computer to the USB connector. Start the OVP software and do the following:
 - Check that the OVP Software is in contact with the actuator (red flashing warning).
 - Open the SETTINGS menu and check the parameter settings.
 - Calibrate by activating Calibration button.
8. Still nothing happens. → Actuator may be in a Calibration routine which has been interrupted. Perform a Calibration to break the ongoing Power Calibration. Then perform a new Manual Power Calibration. NB You need a mechanical stop.
9. If you have replaced a new control board, check all cables and be sure that jumper is there and if it is correct installed. (If using 0-10V controlling, that jumper must be removed). See wiring diagram or take contact with your actuator supplier or Oden Control AB.
10. If you get ERROR messages in right corner (in red) in OVP window. Right click with your mouse **status** bar, then you can see the alarms written.
11. 2 pcs green LED light on control board, means everything is OK

Blocked valve

If the return signal is 2 mA (default) and the actuator does not react on a control signal the valve is probably blocked. Some common reasons for blockage.

1. The necessary torque/force for the valve is not provided by the actuator. Check the setting in OVP. NB for a certain speed, use the maximum torque/force acceptable according to the valve specification. This gives margin to handle increased torque/force valve demands in the future. See point 3 below. Ask your valve supplier for required torque/force, to operate your specific valve.
2. The working range is set to a higher value than the actual possible working range. Check the setting in OVP.
3. The valve has a too hard preloading of the valve gland sealing, bad valve bushings or corroded valve spindle.

To find out if the valve is blocked, one method is to give the actuator a control signal of 10 mA. Then decrease the control signal to 7 mA and thereafter increase to 13 mA. If the actuator starts vibrating for a few seconds and then stops, this indicates a blocked valve.

Another method is to break the power and manually operate the valve to find out if runs smoothly within the working range. If not, the actuator needs to be removed and the necessary torque for moving the valve should be measured and compared to the setting in OVP. Note when you use handwheel, it gives 100 times motor torque.

Calibration problem

If the valve is not closing properly after a Power Calibration the reason may be that the calibration torque/force is not high enough. By default, the calibration torque/force is about 80 % of the control torque/force value set in OVP. If possible, increase the control/force setting in OVP. If this is not possible, please contact your Oden representative.

Problem with power supply to actuator Replacement of fuses. See also photo on page 18.

Check your power supply. Make measurement of your power supply to actuator.

If power supply is ok check fuses on connection board. Look at error flags:

If you have errors: 12V and Isolated AD, check fuse F12.

If you get errors: 12V, isolated AD and V-drive, replace fuse F1(it is soldered) See photo on page 18.

OVP-V problem

OVP-V has no connection with the actuator:

1. Check that you have the USB / USB MINI cable connected to the connection board and computer port and that the port is logical opened. Normally actuator will detect your actuator automatically when you put in USB connector to your computer and actuator.
2. Check that you have 24V DC (or if using 48V DC) to the actuator.

Note, when performing a Calibration from OVP-V the connection to the actuator may be lost. If so, exit OVP-V and enter again. This is a normal behavior.

NOTE! When connecting computer with actuator, put in first MINI USB to actuator, then other end of your USB cable, to your computer!

Basis weight control.

Oden actuators have no pure pulse control yet. Our digital control works like 3-points control. Quite many customers use our V- series actuators for basis weight control successfully. Our actuators have 5000 steps at 90 degrees. Speed can be adjusted from **0, 10 to 15 °/sec**. The digital input (INC, DEC) is not pulsed, but the engine is running as long as they are activated. It is read every millisecond, there is a filter function that removes noise, and it means that the signal needs to be stable at ~35 mS to be detected. If questions, pl.do not hesitate to contact Oden Control AB for more information and references.

TIPS

- If you have any control problem, please go to chapter Trouble shooting. If you still have problem, please contact Oden Control AB.
- When using OVP always check that you are using the latest version. which can easily be downloaded from our website: www.odenccontrol.com
- All parameter settings in OVP are stored in a permanent memory in the electronics.
If the limit of the working range has been exceeded, by entering the password protected Supervisor menu in OVP, no saving occurs. To maintain the calibration, point for an extended working range, you will need to continuously power the actuator, for example by an UPS (Uninterrupted Power Supply). Please contact Oden Control AB for more information.
- Concerning your choice of cable, check that the voltage at the actuator is within 24V DC +/- 15% when the actuator is running. Too low voltage will reduce the output torque of the actuator and may affect the electronic function.
- There are options concerning other types of spindle adapters. Tapered clamping sleeves are alternatives to the traditional method. These sleeves make the installations quicker and easier. Please ask for more specific information.
- If you want to control the actuator locally, close to the actuator, please ask for more specific information. Ask for Oden Remote Box.
- There are options concerning several types of turning and linear units, which are not mentioned in this manual. Please ask for more specific information.
- Visit our website: www.odenccontrol.se for more information. Latest versions of manuals and drawings can be downloaded from this website.

Recycling of the used Oden parts

Oden actuators top flange, housing, assembly flange, magnetic disc, and motor flange, are made of aluminium material and can be recycled. Gear parts, ball bearings and all bolts can be recycled as steel materials. Electric motor, connection board and control board, are e-waste, these materials should be recycled by Certified E-Waste Recycler. Oden actuators do not contain batteries. O-rings and radial seals are in plastic and rubber material, these materials, can be recycled and are broadly being used to produce a wide range of products. Even assembly kits, linear units and other assembly parts are in aluminium or steel material, which can also be recycled.

Fuses on Oden Connection board

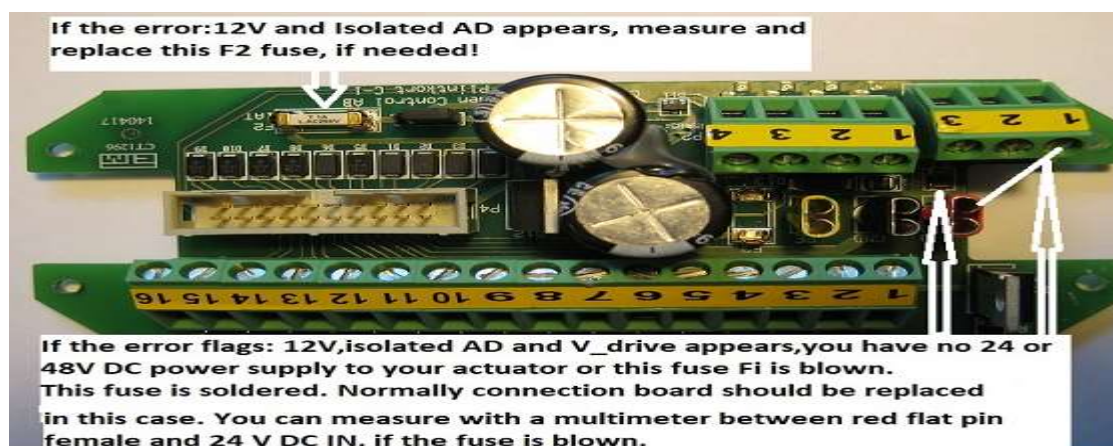

Actuator sizes:

Actuator	Sizes:								
Step	A	B	C	D	E	F	G	H	I
V30	185	150	40	20	20	∅138	116	93	119
V65	202	167	57	37	19	∅138	116	93	119
V180	273	238	128	108	28	∅138	116	93	119
V250	307	272	162	142	28	∅175	152	111	137
V400	331	296	186	166	50	∅175	152	111	137
Servo									
V30Q	251	216	106	86	20	∅138	116	93	119
V65Q	268	233	123	103	19	∅138	116	93	119
*V120Q	296	261	151	131	28	∅175	152	111	137
*V120Q is not available yet !									
Actuator	Connection							Weight:	
Step	J			K				(kg)	
V30	M8 (2x), M8 (4x), M10 (4x)			50 (iso F5), 70 (iso F7), 102 (iso F10)				4,4	
V65	M10 (4x)			102 (iso F10)				5,1	
V180	M10 (4x)			102 (iso F10)				7,7	
V250	M10 (4x), M12 (4x)			102 (iso F10), 125 (iso F12)				13,3	
V400	M12 (2x), M16 (2x)			125 (iso F12), 140 (iso F14)				17	
Servo									
V30Q	M8 (2x), M8 (4x), M10 (4x)			50 (iso F5), 70 (iso F7), 102 (iso F10)				5,8	
V65Q	M10 (4x)			102 (iso F10)				6,5	
*V120Q	M10 (4x), M12 (4x)			102 (iso F10), 125 (iso F12)				12,5	

Several adapter flanges are available to adapt between different ISO F sizes, to mount between actuators and valve tops.

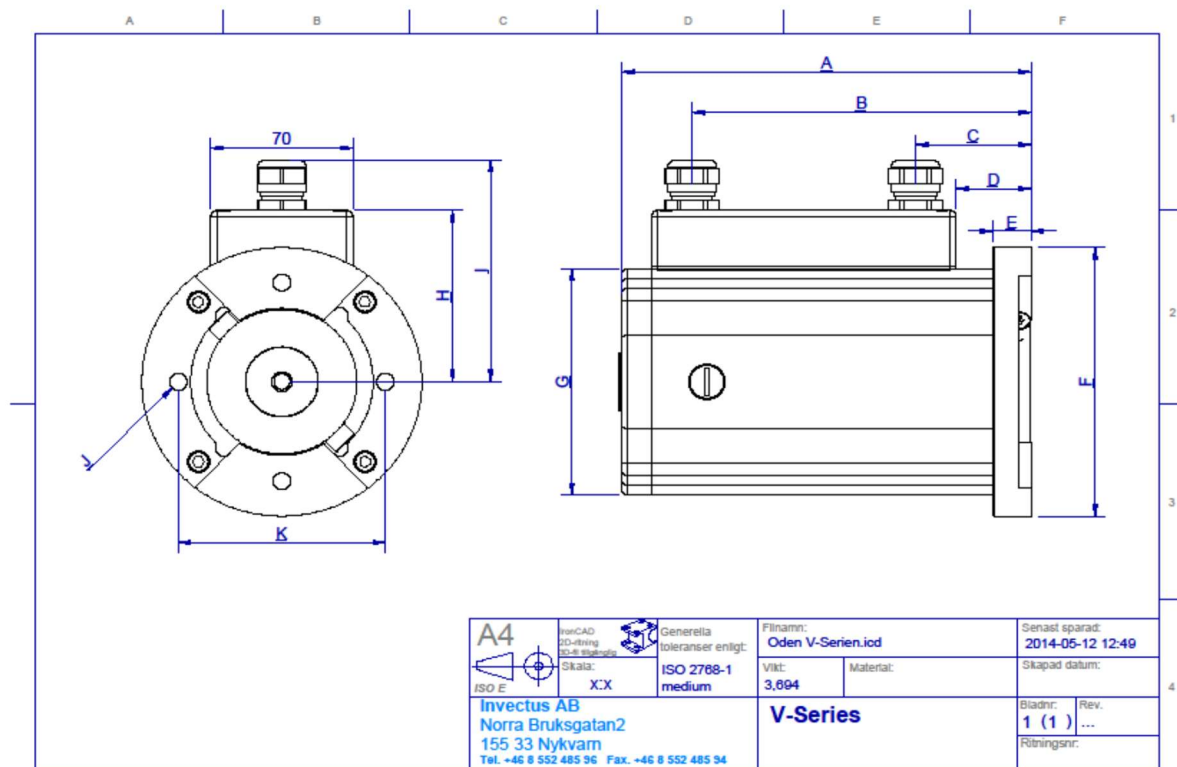

Terminal Board

Manual calibration			Binary input signals			Control signal	Feedback signal		Adjustable limit switches			System alarms			
			ON-OFF 3-POINT			SET POINT	POSITION		OPTOCOUPLERS						
Normally not in use. External power supply to control board	Manual calibration. External limit 1	Manual calibration. External limit 2	L/+ 24VDC. OPEN	L/+ 24VDC. CLOSE	N/- (also manual calibration)	+4...20 mA (0...10V or 2-10V) Note 1	-4...20 mA (0...10V or 2-10V) Note 1	+4...20 mA (feedback) Active	-4...20 mA (feedback) Active	L/+ 24VDC. CLOSE Passive	L/+ 24VDC. OPEN Passive	N/-	L/+ 24VDC. Signal status ok	L/+ 24VDC. Manual/autocalibration mode	N/-
	↓	↓	↓	↓	↓	↓	↓	↑	↑	↓	↓	↓	↑	↑	↓
1	2	3	4	5	6	7	8	9	10	11	12	13	14	15	16

P1

Note1: When 0-10V (or 2-10V) control uses, remove jumper from control board!

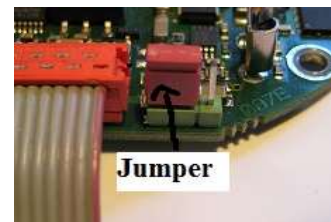
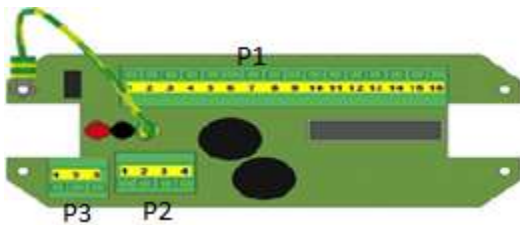

Connections for optocouplers

1	2	3	1	2	3	4
↑	↑	↑	↑	↑	↑	↑
L/+ 24VDC or 48VDC	N/-	PE	VP (24 V DC)	Common (0 V+)	B (-)	A (+)
Power supply			MODBUS RS 485			

P3

P2

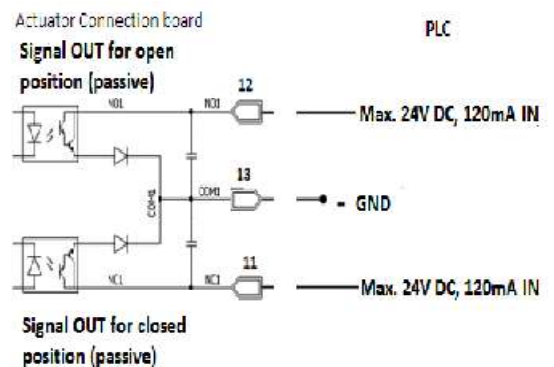

13. Explanations for in and outputs on connection board:

Power supply to actuator:

1. L/+ 24V DC or 48V DC **NOTE! Max 52 V peak! (Look at Output/input limitations, brochure!)**
2. N/-
3. PE

Connection board: Pins 1 to 16:

1. V-LO (normally not IN use). External power supply to control board)
2. Limit 1. Signal IN from external limit switch (open or close) Also manual calibration*¹**max24V.**
3. Limit 2. Signal IN from external limit switch (open or close) Also manual calibration*¹**Max24V!**
4. INC (opens) signal IN DIGITAL and 3-points control 24V DC.
5. DEC (closes) signal IN Digital and 3-points control 24V DC.
6. GND (also for manual calibration use)
7. Control signal IN +4-20mA (for 0-10V control, jumper must be removed from control board)
8. Control signal IN -4-20mA (for 0-10V control, jumper must be removed from control board)
9. Analog feedback signal OUT +4-20mA (NOTE: ACTIVE) Max loop resistance is 700 Ω (TBC)
10. Analog feedback signal OUT -4-20mA (NOTE: ACTIVE) Max loop resistance is 700 Ω (TBC)
11. Signal OUT for CLOSED position NOTE: PASSIVE NPN (Max load 120mA / 24V) *
12. Signal OUT for OPEN position NOTE: PASSIVE NPN (Max load 120mA / 24V) *
13. COM 1 Return for signal for CLOSED and OPEN position (pins 11 and 12)
14. Error status. Will be connected with COM 2, if everything is OK
15. Off-line. Will be connected with COM2, if in MANUAL OVERRIDE or CALIBRATION mode.
16. COM 2 At closed contact current may flow into the terminals 14 and 15 and out through COM2.

ON /OFF control connections: 4 and 5. Actuators will be pre-adjusted for ONOFF control mode by factory.

If the actuator is bought like On-Off actuator, it will be locked to On-Off mode and can only be changed to control actuator by factory. You get the analog position signal from pins 9 and 10.

MODBUS: ask for more information from actuator supplier or Oden Control AB

NOTE: Maximum load for digital outputs is 120 mA! (NPN transistor)

MANUAL CALIBRATION WITHOUT COMPUTER: *¹ NOTE: MAX 24 V DC ONLY!

Actuator can be calibrated for to correct 0 (zero) point and even for open position point (if selected in OVP settings). Make following connections, to make calibration: Connect wire from **Pin 2, 0V (GND)** to Pin 6 (GND in terminal block (in terminal block 1 to 16!)) Then connect wire from pin 2 and 3 (on terminal block with pins from 1 to 16) to **Pin 1** (24V DC power supply on terminal block for incoming power supply) *See diagram down here! Wires from pin 2 and 3 should be twisted in the free end of wire. Put that free end of that wire to screw head for **Pin 1 (24 V DC IN** power supply) Keep connection about 3 sec. then remove connected cables. Now actuator makes calibration and returns to normal run mode.

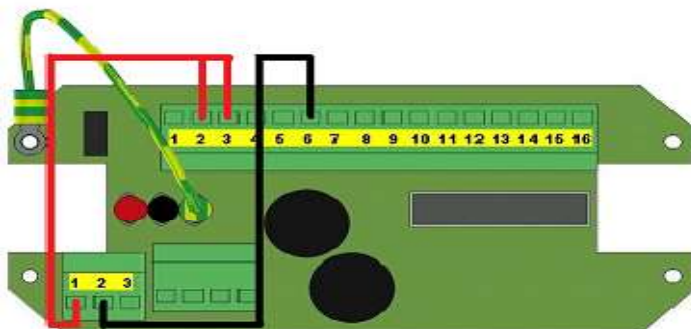

14. Linear actuators and sizes

V30QL

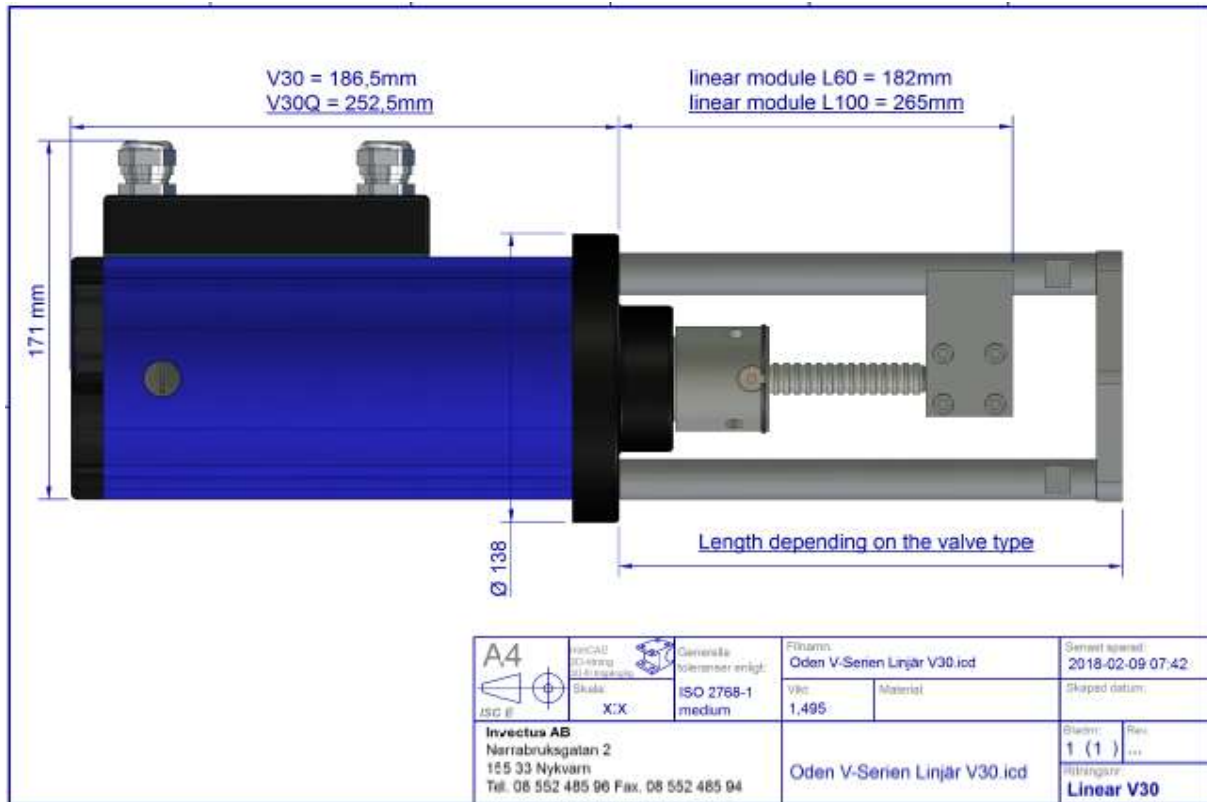

V65QL

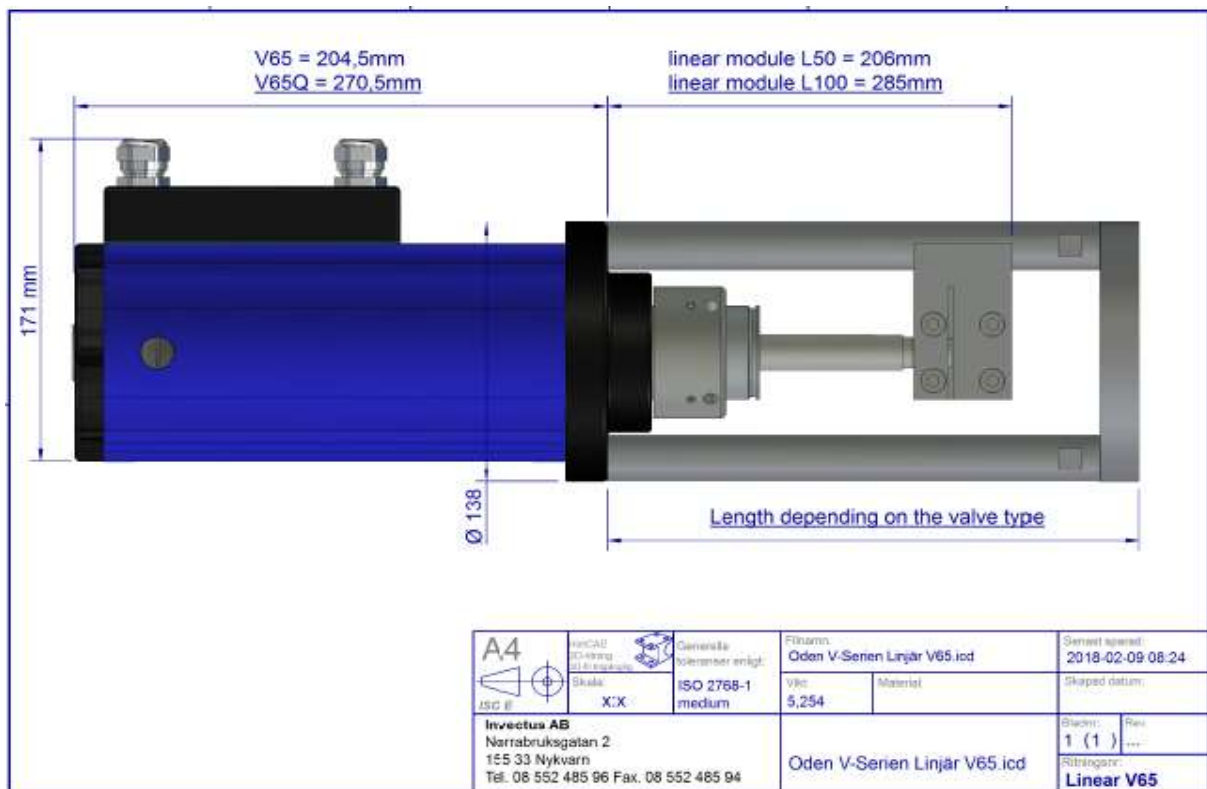

V30Q/V65Q (Q=quick, actuator with servo motor V30QL/V65QL (L= with linear module)

Several lengths of rods and different assembly flanges to valves are available!

Installation help for OVP-V.23A program. Compatible with XP, Windows 7, and newer windows versions.

Note! Password to install the program is: **oden2016**

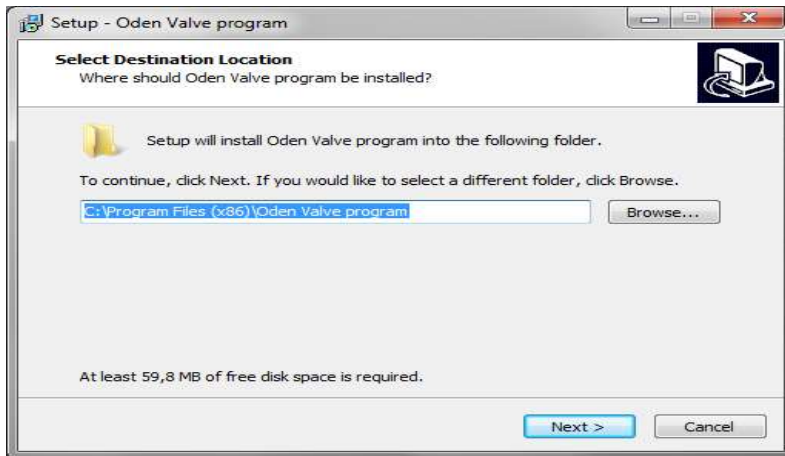

If you have another Oden OVP program version in your computer, select a different folder. If not, press NEXT.

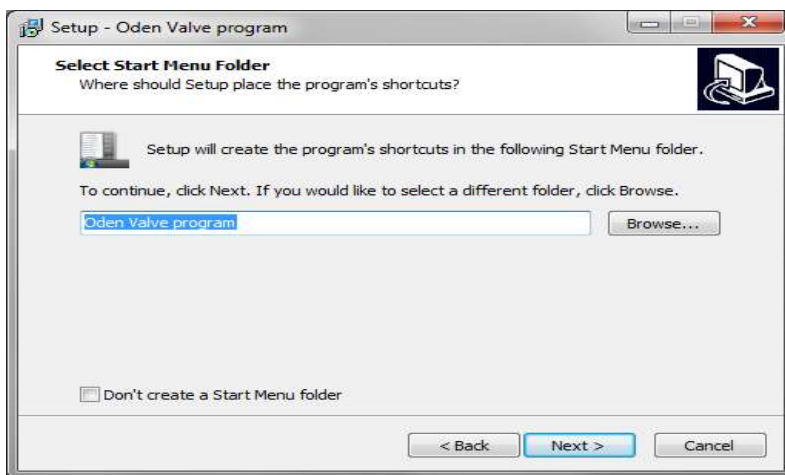

Press: NEXT

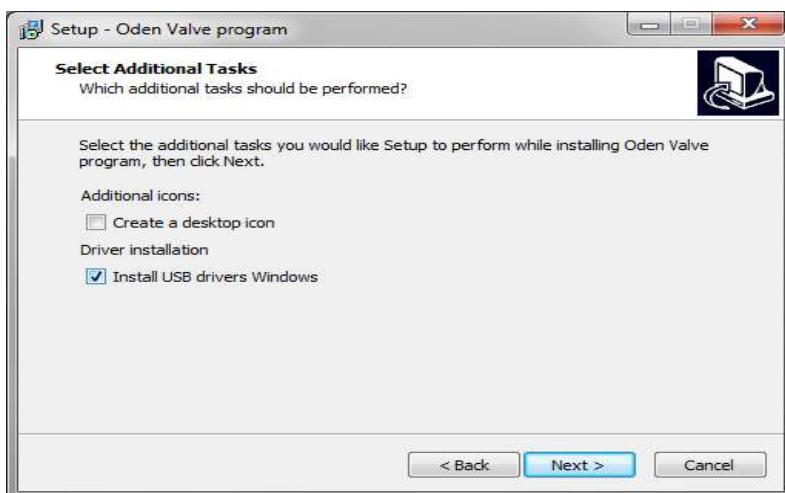

Select: **Install Windows USB drivers**, if you don't have older versions of OVP program in your computer. And here you can choose if you want to create a desktop icon! Then press NEXT!

Go to next page!

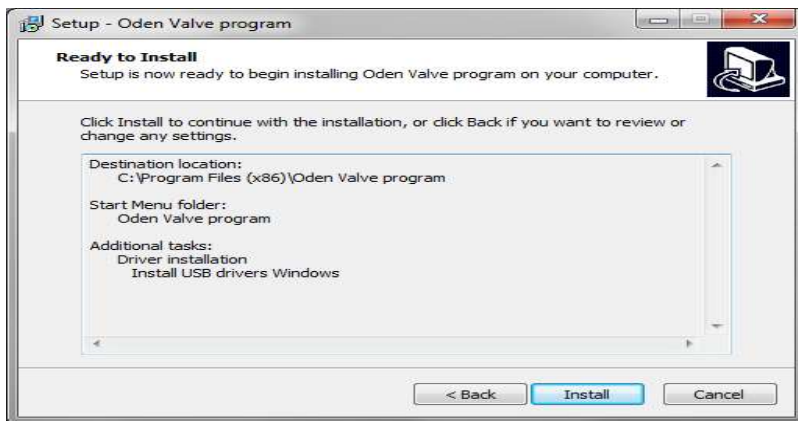

Press: INSTALL

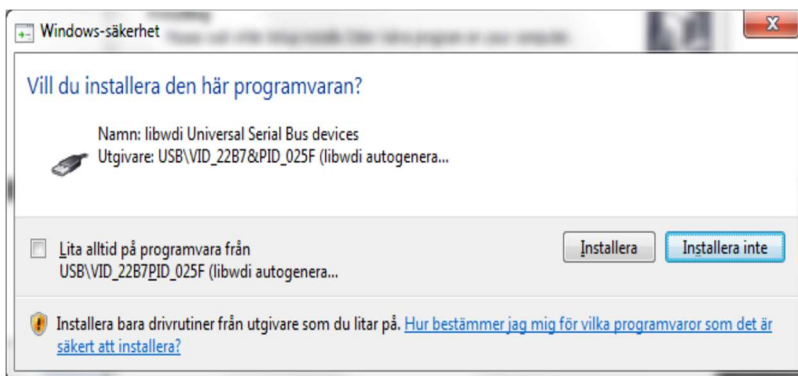

Select: INSTALL (performs installation of serial bus driver)

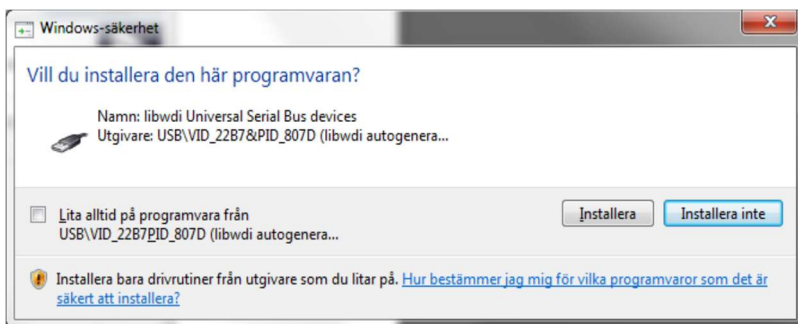

Select: INSTALL (performs installation of serial bus driver)

Open the OVP-V.23A program -

Connect your actuator to computer with USB/USB mini cable.

Now press: CONNECT to make connection with actuator.

Now you can make or change settings. Press APPLY and then SAVE to save settings.

It is possible to save this Oden OVP-V program in USB memory stick and run it from that stick also.

NOTE!

Note: You cannot connect your actuator with older versions (OVP-14 or OVP-17) with OVP-V.23A program.

You must install a new firmware with OVP-14 or OVP-17 program. Then you can use OVP-V.23As program.

Ask your Actuator supplier or Oden Control support for help to get a new firmware and installation help!

DECLARATION OF CONFORMITY

Herewith declares that the product(s):

Oden Control AE: V30, V65, V180, V250, V400, V30Q, V65Q, V30QI, and V65QI, electric actuators

are CE-marked 2023 under full technical responsibility of:

Oden Control AB
Norra Bruksgatan 2
155 33 Nykvarn
Sweden

and in conformity with the provisions of the following EU directive(s):

- Electromagnetic Compatibility (EMC) Directive: 2014/30/EU
- Restriction of the use of certain hazardous substances in electrical and electronic equipment (RoHS): 2011/65/EU

and conforming to the EMC standard(s):

- EN 61000-6-2:2005 + AC:2005 Electromagnetic compatibility (EMC) - Part 6-2: Generic standards - Immunity for industrial environments IEC 61000-6-2:2005
- EN 61000-6-3:2007 + EN 61000-6-3:2007/A1:2011+AC:2012 Electromagnetic compatibility (EMC) - Part 6-3: Generic standards - Emission standard for residential, commercial and light-industrial environments IEC 61000-6-3:2006

and RoHS standard:

- EN IEC 6300:2018 Technical documentation for the assessment of electrical and electronic products with respect to the restriction of hazardous substances

Is hereby declared under our sole responsibility:

Nykvarn, Sweden 2024-11-11

Place and date of authorization



Hani Pernila
Managing Director
Oden Control AB

Lubricant recommendations for Oden V-Series actuators.

At the service of the electric actuators, the recommended fat products should be used for the best function. For **Oden actuator gear parts**, **KLÜBER, ISOFLEX TOPAS NB 52** grease should be used.

Temperature range -50 / +150 C Dropping point 240°C

When servicing or charging fat to **Oden linear devices**, **OILKEY, JET-GREASE GT-500XT** should be used.

Temperature range °C -25 / + 180 Dropping point °C +260

Safety data sheets can be downloaded from www.odencntrl.com / download /

Select: **KLÜBER, ISOFLEX TOPAS NB 52** or **OILKEY, JET-GREASE GT-500XT**

Warranty

Oden V-series actuators has IP67 sealing. Therefore, it is important that the condition of the seals is checked and replaced if necessary, during maintenance of the actuator. All screws must be tightened properly. The actuator contains sensitive electronics, which can be damaged if water or other liquids enter the actuator.

Cable glands for junction box have IP68 sealing. For the warranty terms to apply, the customer, dealer and electrician who will mount the cables to the actuator, must comply with the rules to ensure that the encapsulation is safe and meets at least IP67 requirements and have the same temperature range as actuator have.

If the cables used are thinner than the rubber seals on the cable gland allow, the rubber seals must be replaced with suitable. Kabel glands or cable glands, must be replaced by a cable gland that ensures the tightness of the selected cable. Contact your actuator supplier or contact Oden Control AB. Standard cable glands, delivered by actuators, are made for cable sizes: upper (near actuator top) is made for cable sizes **7-13mm** and the lower is for cable sizes **5-10mm**.

If the customer changes cable glands to a model, which does not guarantee at least IP67 encapsulation or tries to seal, for example, the cable gland with diverse types of sealing compounds for this type of cable gland, the warranty does not apply. If original parts are replaced to non-original, you must talk about the warranty terms with the supplier or Oden Control AB. If only one of the cable glands is in use, the unused cable opening must be sealed with the supplied rubber stopper and tightened tightly.

Note! Only one cable inside in one cable gland!



Cable glands can also be supplied with the model and size required by the customer, provided that at least IP67 encapsulation class is maintained and that the cable gland also meets the requirements in terms of heat resistance. In some cases, such an option may increase the price of the actuator. Talk to your actuator supplier or contact Oden Control AB, for support. The actuator must not be opened if there is a risk of water entering the actuator. On the side of the actuator there are hole for USB cable for programming. The hole is sealed with a metal blind plug with O-ring. This blind plug has IP68 sealing. Blind plug must be tightened properly, after use.

Warranty Period for Oden actuators is 1 year. When longer Warranty Period is needed, take contact with Oden Control AB for more info! If problems appear during warranty time, faulty actuators should be sent to supplier. Normally, telephone or internet support, can solve most of the problems. Life cycle for the oden actuators is about 5-15 years depending on temperature conditions, weather if in outdoor use, number of starts per day and quality of stabile power supply to actuator. Even situations, there the choice of wrong actuator type or wrong settings can cause shorter life cycle. Rules for set IP67 classification, must be followed carefully.

NOTE! (Information about the manual operation)

If your electric actuator was delivered with handwheel or manual operation by hex key. Power supply to actuator must be switched off if the actuator will be operated manually. When the actuator is operated manually with handwheel or with hex key, torque will be about 10 times higher than actuator own torque. Wrong handling can damage stepper motor shaft, control board and gear. See closing direction on yellow sticker on actuator top or handwheel top.



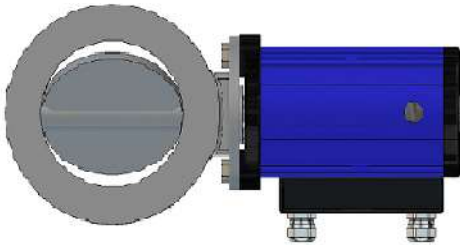
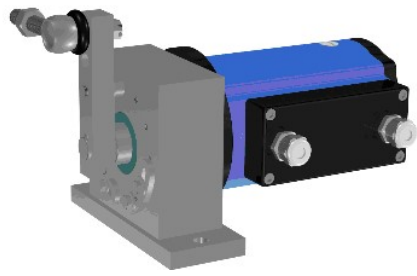

Oden Control AB
Norra Bruksgatan 2
15533 Nykvarn
Sweden

Phone: (+46) 8 767 76 57
E-Mail: oden@odencontrol.com
Web: www.odencontrol.com

